



Age Range: 3-7 Yrs.
 Weight Limit: 65 Lbs.
 Surfaces: Grass & Hard
 Speed: 2.5 / 5.0 MPH Forward
 2.5 MPH Reverse
 Colors: Red Body
 Flame Trim
 Intro: 8-20-99 U.S.
 11-29-99 Canada
 Suggested Retail: \$199.99
 Box Dimensions: 40" x 20" x 25"
 35 Lbs.
 Warranty: One Year Vehicle
 6 Months Battery

74290-9993

Harley Davidson® Motorcycle Advanced Series Non H.E. 12 Volt

This product is affected by the PW Harely recall announced August 31, 2000. Please confirm that the product is modified or remediated in accordance with policy.

3 AA Batteries Required for Soundbox

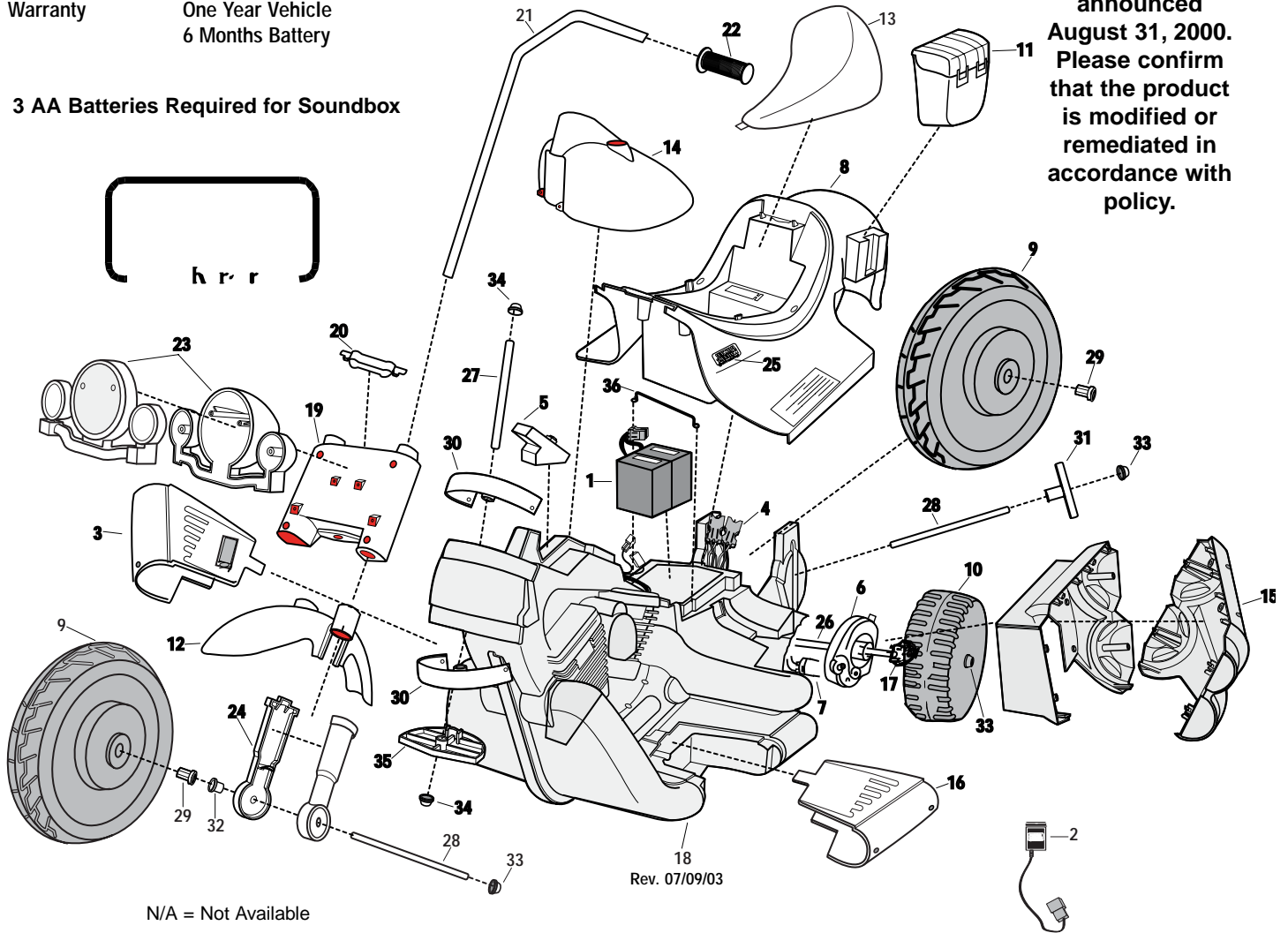

Item No.	Description	Part No.	Qty.	Item No.	Description	Part No.	Qty.	Item No.	Description	Part No.	Qty.
Working / Electrical Parts				14	Gas Tank	74290-214A	1	29	Bushing (hex)	73233-2559	4
1	6 Volt Battery	00801-0712	2	15	Exhaust Set (banded)	74290-9169	1	30	Bushing (steering)	74290-2359	2
2	12V Charger	00801-0973	1	16	Footboard / Left	74290-2249	1	31	Bushing (axle/silver)	74290-2379	2
3	Footboard Assembly w/switch	74290-9239	1	17	Driver	73233-2239	2	32	Bushing (round/black)	74550-2689	2
	When sending the footboard assm please order instruction #74290-0922 for consumer			18	Frame (inc. L & R sides N/A)	74290-9219	1	33	.437 Cap Nut	0801-0226	6
4	Wiring Harness Assembly	74290-9799	1	19	Fork (upper)	74290-2349	1	34	.354 Cap Nut	0801-0604	3
5	Soundbox	74290-9559	1	20	Fork Cover	74290-2389	1	35	Steering Stop	74290-2369	1
6	#7 Motor Gearbox Assm.	00968-2901	2	21	Handlebar Set (banded)	74290-9029	1	36	Battery Retainer	74290-4419	1
7	Motor w/Pinion	74290-9539	2	22	Handgrip	74290-2399*	2	Parts Not Shown			
Plastic / Other Parts				23	Headlight Assembly	74290-9289	1		Decal Sheet	74290-0310	1
8	Body (N/A)	74290-2109	1	24	Shock Set (banded)	74290-9329	1		Literature Bag	74290-9049	1
9	Large Wheel	74290-2159	2	25	PW Emblem	74460-9069	2		Owner's Manual N/A	74290-0920	1
10	Drive Wheel (Small)	74290-2269	2	Hardware / Metal Parts					Small Parts Bag	74290-9259B	1
11	Saddle Bag	74290-2129	2	26	Axle (drive wheel)	74290-4509	1		Hardware Bag	74290-9279	1
12	Front Fender N/A	74290-213A	1	27	Axle (fork)	74290-4529	1		Large Parts Bag	74290-9249	1
13	Seat	74290-2309	1	28	Axle (wheel)	74290-4519	2		Gearbox W/Out Motor	00968-2801	1
									Control Switch	00801-0873	2
									3/4" Plastite Screw	0912-8001	55

Bold and Underlined parts are to be purchased and installed by Service Centers only. These items may not be sold directly to consumers by Service Centers or Fisher-Price.